



# **DEEP SEA ELECTRONICS PLC**

## **DSE2133 DSEnet RTD / Thermocouple Input Expansion Module Operator Manual**

**Document number 057-140**

Author : Anthony Manton



Deep Sea Electronics Plc  
Highfield House  
Hunmanby  
North Yorkshire  
YO14 0PH  
ENGLAND

Sales Tel: +44 (0) 1723 890099  
Sales Fax: +44 (0) 1723 893303

E-mail : sales@Deepseapl.com  
Website : www.deepseapl.com

#### DSE2133 DSEnet RTD / Thermocouple Input Expansion Module

© Deep Sea Electronics Plc

All rights reserved. No part of this publication may be reproduced in any material form (including photocopying or storing in any medium by electronic means or other) without the written permission of the copyright holder except in accordance with the provisions of the Copyright, Designs and Patents Act 1988.

Applications for the copyright holder's written permission to reproduce any part of this publication should be addressed to Deep Sea Electronics Plc at the address above.

Any reference to trademarked product names used within this publication is owned by their respective companies.

Deep Sea Electronics Plc reserves the right to change the contents of this document without prior notice.

#### Amendments since last publication

Amd. No.	Comments
1	First release
1.1	Corrected supported RTD table.

Typeface : The typeface used in this document is *Arial*. Care should be taken not to mistake the upper case letter I with the numeral 1. The numeral 1 has a top serif to avoid this confusion.

## Table of contents

<b>1</b>	<b>BIBLIOGRAPHY</b> .....	<b>4</b>
<b>2</b>	<b>INTRODUCTION</b> .....	<b>4</b>
<b>3</b>	<b>SPECIFICATIONS</b> .....	<b>5</b>
3.1	<b>PART NUMBERING</b> .....	<b>5</b>
3.1	<b>POWER SUPPLY</b> .....	<b>5</b>
3.2	<b>TERMINAL SPECIFICATION</b> .....	<b>5</b>
3.3	<b>INPUTS</b> .....	<b>6</b>
3.3.1	RTD INPUTS.....	<b>6</b>
3.3.2	THERMOCOUPLE INPUTS.....	<b>6</b>
3.4	<b>DSENET®</b> .....	<b>6</b>
3.5	<b>DIMENSIONS</b> .....	<b>7</b>
3.6	<b>APPLICABLE STANDARDS</b> .....	<b>8</b>
<b>4</b>	<b>INSTALLATION</b> .....	<b>9</b>
4.1	<b>USER CONNECTIONS</b> .....	<b>9</b>
4.1.1	CONNECTOR A.....	<b>9</b>
4.1.2	CONNECTOR B.....	<b>9</b>
4.2	<b>SCHEMATIC INTERCONNECTION DIAGRAM</b> .....	<b>10</b>
4.3	<b>TYPICAL WIRING DIAGRAM</b> .....	<b>10</b>
<b>5</b>	<b>CONTROLS AND INDICATIONS</b> .....	<b>11</b>
5.1	<b>LED INDICATIONS</b> .....	<b>11</b>
5.2	<b>ID SWITCH</b> .....	<b>11</b>
<b>6</b>	<b>FAULT DIAGNOSIS</b> .....	<b>12</b>
<b>7</b>	<b>MAINTENANCE, SPARES, REPAIR AND SERVICING</b> .....	<b>12</b>
<b>8</b>	<b>WARRANTY</b> .....	<b>12</b>
<b>9</b>	<b>DISPOSAL</b> .....	<b>12</b>
9.1	<b>WEEE (WASTE ELECTRICAL AND ELECTRONIC EQUIPMENT)</b> .....	<b>12</b>
9.2	<b>ROHS (RESTRICTION OF HAZARDOUS SUBSTANCES)</b> .....	<b>12</b>

## 1 BIBLIOGRAPHY

This document refers to and is referred to by the following DSE publications which can be obtained from the DSE website [www.deepseapl.com](http://www.deepseapl.com)

DSE PART	DESCRIPTION
057-115	8610 operator manual
057-119	8600 series configuration software manual

## 2 INTRODUCTION

This document details the installation requirements of the DSE2133 RTD / Thermocouple input expansion module part of the DSENet® range of ancilliary devices.

The manual forms part of the product and should be kept for the entire life of the product. If the product is passed or supplied to another party, ensure that this document is passed to them for reference purposes.

This is not a *controlled document*. You will not be automatically informed of updates. Any future updates of this document will be included to the DSE website at [www.deepseapl.com](http://www.deepseapl.com)

DSE2133 input expansion module is used in conjunction with supported DSE controllers to provide additional input functionality (8 RTD / Thermocouple inputs ). The inputs are configured in the 'host controller', the DSE2133 module is not itself configured apart from the 'ID switch'.

For further details on configuring the 'host controller' you are referred to the relevant configuration software manual (refer to the section entitled *Bibliography* elsewhere in this document).

### 3 SPECIFICATIONS

#### 3.1 PART NUMBERING

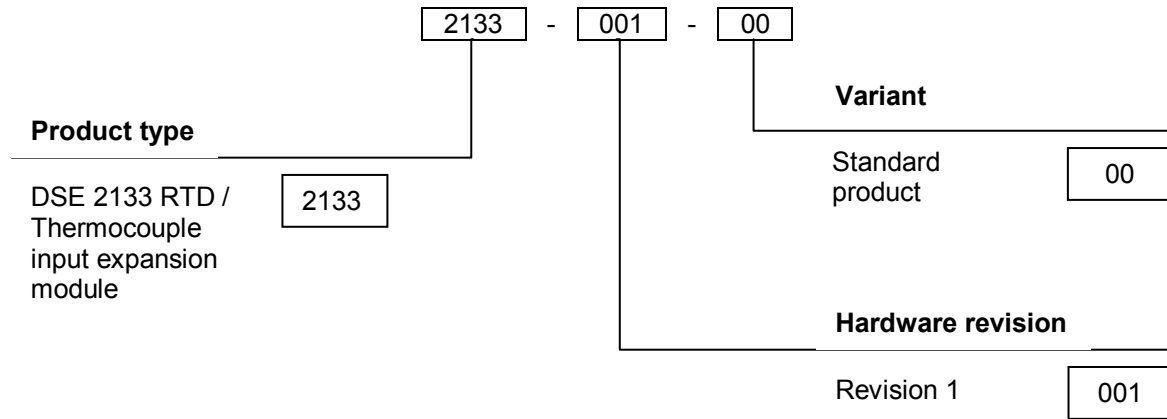

At the time of this document production, there are no variants of this product and there have been no revisions of the module hardware.

#### 3.1 POWER SUPPLY

Minimum supply voltage	8V continuous, 4V for up to 5 minutes.
Cranking dropouts	Able to survive 0V for 50mS providing the supply was at least 10V before the dropout and recovers to 5 volts afterwards.
Maximum supply voltage	35V continuous (protection to 60V)
Maximum operating current	56mA at 12V, 20mA at 24V Conditions: All inputs configured as 3 wire PT100
Minimum operating current	50mA at 12V, 18mA at 24V Conditions: All inputs configured as thermocouple

#### 3.2 TERMINAL SPECIFICATION

Connection type	Screw terminal, rising clamp, no internal spring
Min cable size	0.5mm <sup>2</sup> (AWG 20)
Max cable size	2.5mm <sup>2</sup> (AWG 14)

### 3.3 INPUTS

#### 3.3.1 RTD INPUTS

Type	Min Temp (°C)	Max Temp (°C)	R @ Min Temp (Ω)	R @ Max Temp (Ω)
PT100	-200	+850	15	400

#### 3.3.2 THERMOCOUPLE INPUTS

##### *Thermocouples*

Type	Min Temp (°C)	Max Temp (°C)	V @ Min Temp (mV)	V @ Max Temp (mV)
J type	-40	+750	-2	+43
K type	-200	+1350	-6	+55

### 3.4 DSENET®

DSEnet is the interconnection cable between the host controller and the expansion module(s) and must not be connect to any device other than DSE equipment designed for connection to the DSEnet.

Cable type	Two core screened twisted pair
Cable characteristic impedance	120Ω
Recommended cable	Belden 9841 Belden 9271
Maximum cable length	1000m (1km) when using Belden 9841 or direct equivalent. 500m (0.5km) when using Belden 9271 or direct equivalent.
DSEnet topology	Bus with no stubs (spurs)
DSEnet termination	120Ω. Fitted internally to host controller. Must be fitted externally to the 'last' expansion module by the customer .
Maximum expansion modules	Refer to host controller documentation

**NOTE :** As a termination resistor is internally fitted to the host controller, the host controller must be the 'first' unit on the DSEnet. A termination resistor **MUST** be fitted to the 'last' unit on the DSEnet. For connection details, you are referred to the section entitled '*typical wiring diagram*' elsewhere in this document.

## Specifications

### 3.5 DIMENSIONS

Overall size	164.6mm x 76.4mm x 48.9mm (6.48" x 3.01" x 1.93")
Weight	150g (0.6lb)
Mounting type	DIN rail or chassis mounting
Din rail type	EN 50022 35mm type only
Mounting holes	M4 clearance
Mounting hole centres	152.37mm x 64.50mm (6.00" x 2.54")

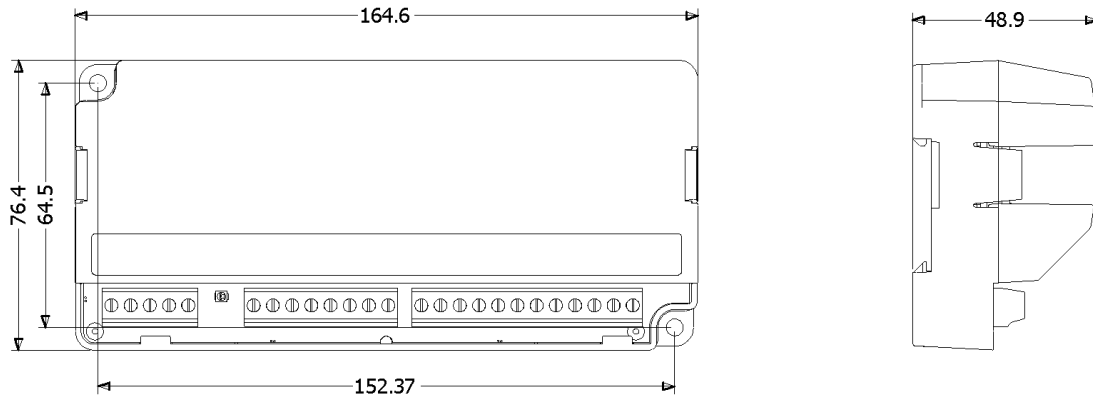

Dimensions in mm

### 3.6 APPLICABLE STANDARDS

<b>BS 4884-1:1992</b>	This document conforms to BS4884-1 1992 Specification for presentation of essential information.
<b>BS 4884-2:1993</b>	This document conforms to BS4884-2 1993 Guide to content
<b>BS 4884-3:1993</b>	This document conforms to BS4884-3 1993 Guide to presentation
<b>BS EN 60068-2-1</b> (Minimum temperature)	-30°C (-22°F)
<b>BS EN 60068-2-2</b> (Maximum temperature)	+70°C (158°F)
<b>BS EN 60950</b>	Safety of information technology equipment, including electrical business equipment
<b>BS EN 61000-6-2</b>	EMC Generic Immunity Standard (Industrial)
<b>BS EN 61000-6-4</b>	EMC Generic Emission Standard (Industrial)
<b>BS EN 60529</b> (Degrees of protection provided by enclosures)	IP21
<b>UL508</b> <b>NEMA rating</b>	enclosure type 1 (indoor use only)

In line with our policy of continual development, Deep Sea Electronics, reserve the right to change specification without notice.



## 4 INSTALLATION

The DSE2133 is designed to be mounted within a control panel, either on the panel DIN rail utilising the integral mounts, or chassis mounted, utilising the mounting holes. For dimension and mounting details, see the section entitled *Specification, Dimensions* elsewhere in this document.

### 4.1 USER CONNECTIONS

#### 4.1.1 CONNECTOR A

Terminal	Function	Recommended size	Notes
1	DC supply positive	1.0mm <sup>2</sup> (AWG18)	
2	DC supply negative	1.0mm <sup>2</sup> (AWG18)	
3	Screen		DSEnet only
4	A	0.5mm <sup>2</sup> (AWG20)	DSEnet only
5	B	0.5mm <sup>2</sup> (AWG20)	DSEnet only

#### 4.1.2 CONNECTOR B

See typical wiring diagram for connection options.

Terminal	Function	Recommended size
6	Channel A +	0.5mm <sup>2</sup> (AWG20)
7	Channel A -	0.5mm <sup>2</sup> (AWG20)
8	Channel B +	0.5mm <sup>2</sup> (AWG20)
9	Channel B -	0.5mm <sup>2</sup> (AWG20)
10	RTD 3 <sup>rd</sup> wire: Channel A & B	0.5mm <sup>2</sup> (AWG20)
11	Channel C +	0.5mm <sup>2</sup> (AWG20)
12	Channel C -	0.5mm <sup>2</sup> (AWG20)
13	Channel D +	0.5mm <sup>2</sup> (AWG20)
14	Channel D -	0.5mm <sup>2</sup> (AWG20)
15	RTD 3 <sup>rd</sup> wire: Channel C & D	0.5mm <sup>2</sup> (AWG20)
16	Channel E +	0.5mm <sup>2</sup> (AWG20)
17	Channel E -	0.5mm <sup>2</sup> (AWG20)
18	Channel F +	0.5mm <sup>2</sup> (AWG20)
19	Channel F -	0.5mm <sup>2</sup> (AWG20)
20	RTD 3 <sup>rd</sup> wire: Channel E & F	0.5mm <sup>2</sup> (AWG20)
21	Channel G +	0.5mm <sup>2</sup> (AWG20)
22	Channel G -	0.5mm <sup>2</sup> (AWG20)
23	Channel H +	0.5mm <sup>2</sup> (AWG20)
24	Channel H -	0.5mm <sup>2</sup> (AWG20)
25	RTD 3 <sup>rd</sup> wire: Channel G & H	0.5mm <sup>2</sup> (AWG20)

## 4.2 SCHEMATIC INTERCONNECTION DIAGRAM

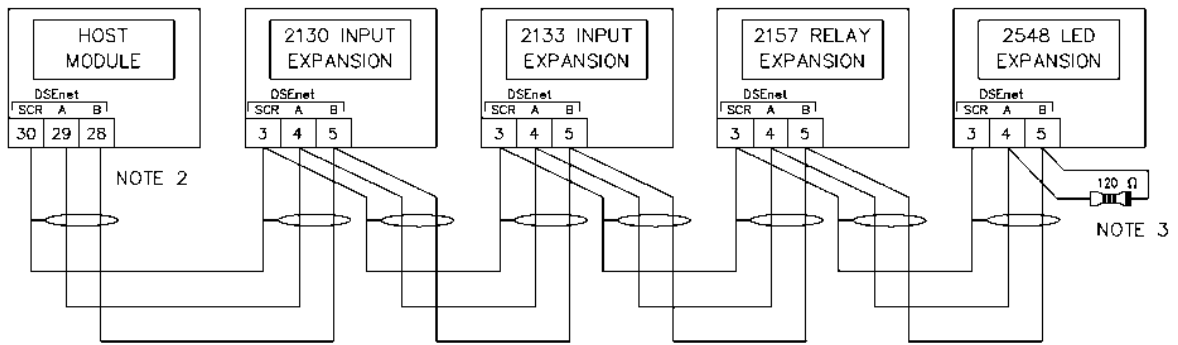

NOTE 2  
 AS A TERMINATING RESISTOR IS INTERNALLY FITTED TO THE HOST CONTROLLER, THE HOST CONTROLLER MUST BE THE FIRST UNIT ON THE DSEnet

NOTE 3  
 A 120 OHM TERMINATION RESISTOR MUST BE FITTED TO THE LAST UNIT ON THE DSEnet

## 4.3 TYPICAL WIRING DIAGRAM

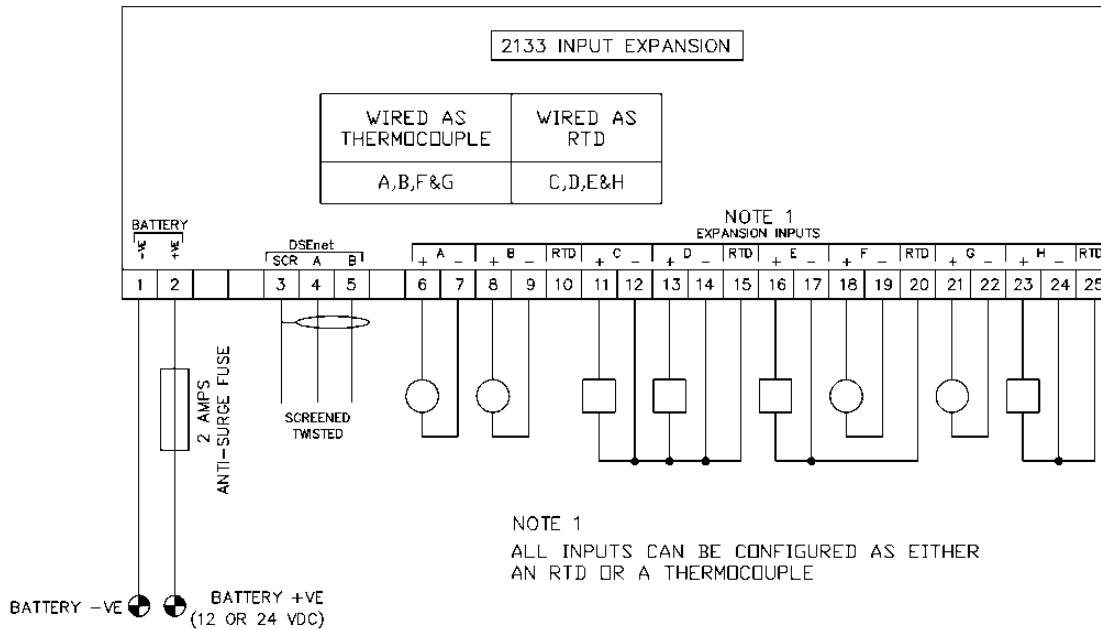

**NOTE :** Configuration of the inputs is performed in the host controller.

## 5 CONTROLS AND INDICATIONS

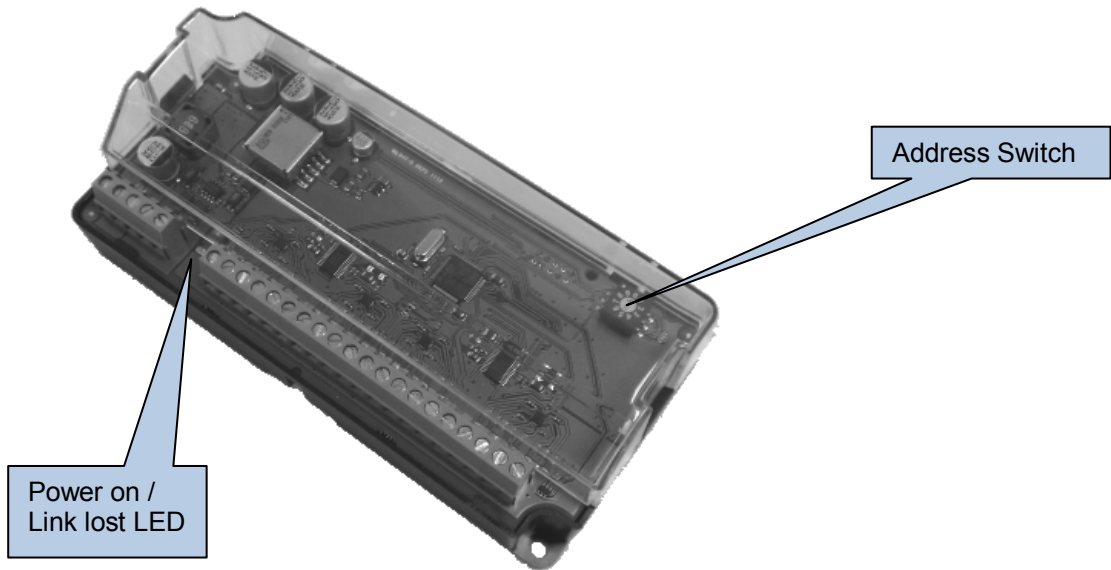

### 5.1 LED INDICATIONS

Function	Colour	Action
Power on / Link lost	RED	Steady when DC supply is connected and data is being received from the host controller. Flashing when the DC supply is connected and the data connection to the host controller is not operating.

### 5.2 ID SWITCH

The rotary ID switch is used to select the 'Identification' of the DSE2133 expansion module as the host controller is capable of giving instructions to a number of DSE2133 expansion modules at the same time. Consult the relevant module's operating instructions for further details on number of supported expansion units (refer to the section entitled *Bibliography* elsewhere in this document).

The enclosure cover must be unclipped and removed to gain access to the switch. The switch should be operated using a small screwdriver and set to match the required ID.

**NOTE :** The ID must be set to be a unique number, different from the ID of any other DSE2133 input expansion module connected on the DSEnet. The ID of the DSE2133 will not interfere with the ID of any other type of expansion module. For instance it's OK to have a DSE2133 with ID1 and a 2157 with ID1. As the two modules are different type

## 6 FAULT DIAGNOSIS

Nature of problem	Suggestion
Inputs don't activate on the host controller	Ensure the host controller is correctly configured to accept the module.
Power LED indication does not illuminate	Check polarity and size of the connected DC supply are within the specifications.
Power LED flashes	This means the the communications link to the host controller has been lost. Check the connection of the DSEnet paying particular attention to the cable type being used and the positioning of the termination resistors.

## 7 MAINTENANCE, SPARES, REPAIR AND SERVICING

The module is designed to be *Fit and Forget*. As such, there are no user serviceable parts. In the case of malfunction you should contact your original equipment supplier (OEM).

## 8 WARRANTY

DSE provides limited warranty to the equipment purchaser at the point of sale. For full details of any applicable warranty, you are referred to your original equipment supplier (OEM).

## 9 DISPOSAL

### 9.1 WEEE (WASTE ELECTRICAL AND ELECTRONIC EQUIPMENT)

Directive 2002/96/EC

If you use electrical and electronic equipment you must store, collect, treat, recycle and dispose of WEEE separately from your other waste.



### 9.2 ROHS (RESTRICTION OF HAZARDOUS SUBSTANCES)

Directive 2002/95/EC:2006

To remove specified hazardous substances (Lead, Mercury, Hexavalent Chromium, Cadmium, PBB & PBDE's)

Exemption Note: Category 9. (Monitoring & Control Instruments) as defined in Annex 1B of the WEEE directive will be exempt from the RoHS legislation. This was confirmed in the August 2005 UK's Department of Trade and Industry RoHS REGULATIONS Guide (Para 11).

Despite this exemption DSE has been carefully removing all non RoHS compliant components from our supply chain and products.

When this is completed a Lead Free & RoHS compatible manufacturing process will be phased into DSE production.

This is a process that is almost complete and is being phased through different product groups.