



# DEEP SEA ELECTRONICS

## DSE73xx MKII Conversion to DSE25xx MKII Remote Display Manual

Document Number 057-278

Author : Fady Atallah





Deep Sea Electronics Ltd  
Highfield House  
Hunmanby  
North Yorkshire  
YO14 0PH  
ENGLAND

Sales Tel: +44 (0) 1723 890099

E-mail : sales@deepseaelectronics.com

Website : www.deepseaelectronics.com

## DSE73xx MKII Conversion to DSE25xx MKII Remote Display Manual

© Deep Sea Electronics Ltd

All rights reserved. No part of this publication may be reproduced in any material form (including photocopying or storing in any medium by electronic means or other) without the written permission of the copyright holder except in accordance with the provisions of the Copyright, Designs and Patents Act 1988.

Applications for the copyright holder's written permission to reproduce any part of this publication must be addressed to Deep Sea Electronics Ltd at the address above.

The DSE logo and the names DSEGenset® are UK registered trademarks of Deep Sea Electronics Ltd.

Any reference to trademarked product names used within this publication is owned by their respective companies.

Deep Sea Electronics Ltd reserves the right to change the contents of this document without prior notice.

### Amendments since last publication

Amd. No.	Comments
1	Initial release
2	Added notes and content regarding RS485 and DSENET® connections, clarifying the application of each port.
3	Added sections to cover various connection methods between DSE25xx MKII and DSE7xxx MKII modules. Diagrams of connection methods included.

Typeface : The typeface used in this document is *Arial*. Care should be taken not to mistake the upper case letter I with the numeral 1. The numeral 1 has a top serif to avoid this confusion.

## TABLE OF CONTENTS

Section	Page
<b>1 INTRODUCTION.....</b>	<b>5</b>
1.1 CLARIFICATION OF NOTATION.....	6
1.2 GLOSSARY OF TERMS.....	6
1.3 BIBLIOGRAPHY.....	7
1.3.1 INSTALLATION INSTRUCTIONS.....	7
1.3.2 MANUALS.....	7
<b>2 SPECIFICATION.....</b>	<b>8</b>
2.1 OPERATING TEMPERATURE.....	8
2.1.1 OPTIONAL SCREEN HEATER OPERATION.....	8
2.2 REQUIREMENTS FOR UL.....	8
2.3 TERMINAL SPECIFICATION.....	9
2.4 POWER SUPPLY REQUIREMENTS.....	9
2.5 DIGITAL INPUT.....	9
2.6 OUTPUTS E & F.....	10
2.7 COMMUNICATION PORTS.....	10
2.8 COMMUNICATION PORT USAGE.....	11
2.8.1 USB SLAVE PORT (PC CONFIGURATION).....	11
2.8.2 RS232 PORT.....	12
2.8.2.1 REMOTE DISPLAY CONNECTION.....	12
2.8.2.2 MODBUS PASSTHROUGH CONNECTION.....	12
2.8.2.3 CABLE SPECIFICATION.....	13
2.8.3 RS485 PORT.....	14
2.8.3.1 DSENET EXPANSION CONNECTION.....	14
2.8.3.2 MODBUS PASSTHROUGH CONNECTION.....	14
2.8.3.3 CABLE SPECIFICATION.....	15
2.8.4 DSENET®.....	16
2.8.4.1 REMOTE DISPLAY CONNECTION.....	16
2.8.4.2 CABLE SPECIFICATION.....	17
2.9 SOUNDER.....	18
2.10 DIMENSIONS AND MOUNTING.....	19
2.10.1 DIMENSIONS.....	19
2.10.2 PANEL CUTOUT.....	19
2.10.3 WEIGHT.....	19
2.10.4 FIXING CLIPS.....	20
2.10.5 CABLE TIE FIXING POINTS.....	21
2.10.6 SILICON SEALING GASKET.....	21
2.11 APPLICABLE STANDARDS.....	22
2.11.1 ENCLOSURE CLASSIFICATIONS.....	23
2.11.1.1 IP CLASSIFICATIONS.....	23
2.11.1.2 NEMA CLASSIFICATIONS.....	24
<b>3 CONVERSION.....</b>	<b>25</b>
3.1 UPDATE FIRMWARE.....	25
<b>4 INSTALLATION.....</b>	<b>28</b>
4.1 USER CONNECTIONS.....	28
4.1.1 RS232.....	29
4.1.2 USB SLAVE (PC CONFIGURATION) CONNECTOR.....	29
4.2 TYPICAL WIRING DIAGRAM.....	30
4.2.1 WIRING TO A DSE7XXX MKII MODULE.....	31
<b>5 CONTROLS AND INDICATIONS.....</b>	<b>32</b>
<b>6 FRONT PANEL CONFIGURATION.....</b>	<b>33</b>
6.1 ACCESSING THE 'RUNNING' CONFIGURATION EDITOR.....	34
6.1.1 EDITING A PARAMETER.....	34

6.1.2	ADJUSTABLE PARAMETERS (RUNNING EDITOR) .....	35
<b>7</b>	<b>MAINTENANCE, SPARES, REPAIR AND SERVICING .....</b>	<b>36</b>
7.1	PURCHASING ADDITIONAL FIXING CLIPS FROM DSE .....	36
7.2	PURCHASING ADDITIONAL SEALING GASKET FROM DSE .....	36
<b>8</b>	<b>FAULT DIAGNOSIS .....</b>	<b>37</b>
<b>9</b>	<b>WARRANTY .....</b>	<b>37</b>
<b>10</b>	<b>DISPOSAL .....</b>	<b>37</b>
10.1	WEEE (WASTE ELECTRICAL AND ELECTRONIC EQUIPMENT) .....	37

## 1 INTRODUCTION

This document details the conversion of DSE73xx MKII controllers to DSE25xx MKII remote display modules and the operation of DSE25xx MKII modules following conversion.

The manual forms part of the product and should be kept for the entire life of the product. If the product is passed or supplied to another party, ensure that this document is passed to them for reference purposes.

This is not a *controlled document*. You will not be automatically informed of updates. Any future updates of this document will be included to the DSE website at [www.deepseaelectronics.com](http://www.deepseaelectronics.com)

The DSE25xx MKII display module is available as a firmware update to convert the DSE73xx MKII modules. The DSE25xx MKII remote display module is used in conjunction with either DSE73xx MKII or DSE74xx MKII controllers to provide remote monitoring and control. Configuration is made in the configuration of the host controller, and in the display module itself.

For further details on configuring the 'host controller' you are referred to the relevant configuration software manual (refer to the section entitled *Bibliography* elsewhere in this document).

The DSE25xx MKII series display operates by mimicking the host controller. This means that the display shows the same information as on the screen of the host controller, depending upon what buttons have been pressed on either unit. For instance, when the host controller is showing the engine information page, the DSE25xx MKII display also shows the engine information page. As the operator presses the buttons to navigate to this display, both units navigate the pages simultaneously.

When two DSE25xx MKII displays are connected to the host controller, they both display the same information as the host. For instance, selecting engine instruments on the host controller also displays engine instruments on both of the connected DSE25xx MKII displays.



Monitoring of the communications link to the host controller is provided to allow an alarm to be generated in the case of a communications link failure. This alarm is configurable in the host controller.

Using a PC and the DSE Configuration Suite software allows alteration of selected configuration parameters. Additionally, the module's integral front panel running editor allows adjustment of this information.

The module is housed in a robust plastic case suitable for panel mounting. Connections to the module are via locking plug and sockets.

## 1.1 CLARIFICATION OF NOTATION

Clarification of notation used within this publication.

 <b>NOTE:</b>	Highlights an essential element of a procedure to ensure correctness.
 <b>CAUTION!</b>	Indicates a procedure or practice, which, if not strictly observed, could result in damage or destruction of equipment.
 <b>WARNING!</b>	Indicates a procedure or practice, which could result in injury to personnel or loss of life if not followed correctly.

## 1.2 GLOSSARY OF TERMS

Term	Description
DSE2000 MKII, DSE2xxx MKII	All modules in the DSE2xxx MKII range.
DSE2500 MKII, DSE25xx MKII	All modules in the DSE25xx MKII range.
DSE2510 MKII	DSE2510 MKII remote display module
DSE2520 MKII	DSE2520 MKII remote display module
BMS	Building Management System A digital/computer based control system for a building's infrastructure.
HMI	Human Machine Interface A device that provides a control and visualisation interface between a human and a process or machine.
SCADA	Supervisory Control And Data Acquisition A system that operates with coded signals over communication channels to provide control and monitoring of remote equipment

## 1.3 BIBLIOGRAPHY

This document refers to, and is referred by the following DSE publications which are obtained from the DSE website: [www.deepseaelectronics.com](http://www.deepseaelectronics.com) or by contacting DSE technical support: [support@deepseaelectronics.com](mailto:support@deepseaelectronics.com).

### 1.3.1 INSTALLATION INSTRUCTIONS

Installation instructions are supplied with the product in the box and are intended as a 'quick start' guide only.

DSE Part	Description
053-181	DSE7310 MKII & DSE7320 MKII Installation Instructions
053-191	DSE7410 MKII & DSE7420 MKII Installation Instructions

### 1.3.2 MANUALS

This document contains only a subset of the operator instructions for the system. For full operating instructions, consult the relevant documents below.

DSE Part	Description
057-004	Electronic Engines and DSE Wiring Manual
057-243	DSE7310 MKII & DSE7320 MKII Software Manual
057-253	DSE7310 MKII & DSE7320 MKII Operator Manual
057-262	DSE7410 MKII & DSE7420 MKII Software Manual
057-263	DSE7410 MKII & DSE7420 MKII Operator Manual
057-279	DSE2510 MKII & DSE2520 MKII Software Manual

## 2 SPECIFICATION

### 2.1 OPERATING TEMPERATURE

Module	Specification
DSE73xx MKII	-30 °C +70 °C (-22 °F +158 °F)
Display Heater Variants	-40 °C +70 °C (-40 °F +158 °F)

#### 2.1.1 OPTIONAL SCREEN HEATER OPERATION

Screen Heater Function	Specification
Turn On When Temperature Falls Below	-10 °C (+14 °F)
Turn Off When Temperature Rises Above	-5 °C (+23 °F)

### 2.2 REQUIREMENTS FOR UL

Description	Specification
Screw Terminal Tightening Torque	4.5 lb-in (0.5 Nm)
Conductors	<p>Terminals suitable for connection of conductor size AWG 20 to AWG 13 (0.5 mm<sup>2</sup> to 2.5 mm<sup>2</sup>).</p> <p>Conductor protection must be provided in accordance with NFPA 70, Article 240</p> <p>Low voltage circuits (35 V or less) must be supplied from the engine starting battery or an isolated secondary circuit.</p> <p>The communication, sensor, and/or battery derived circuit conductors shall be separated and secured to maintain at least ¼" (6 mm) separation from the generator and mains connected circuit conductors unless all conductors are rated 600 V or greater.</p>
Current Inputs	Must be connected through UL Listed or Recognized isolating current transformers with the secondary rating of 5 A max.
Communication Circuits	Must be connected to communication circuits of UL Listed equipment
Output Pilot Duty	0.5 A
Mounting	<p>Suitable for use in type 1 Enclosure Type rating with surrounding air temperature -22 °F to +158 °F (-30 °C to +70 °C)</p> <p>Suitable for pollution degree 3 environments when voltage sensing inputs do not exceed 300 V. When used to monitor voltages over 300 V device to be installed in an unventilated or filtered ventilation enclosure to maintain a pollution degree 2 environment.</p>
Operating Temperature	-22 °F to +158 °F (-30 °C to +70 °C)
Storage Temperature	-40 °F to +176 °F (-40 °C to +80 °C)



### 2.3 TERMINAL SPECIFICATION

Description	Specification	
Connection Type	Two part connector. Male part fitted to module Female part supplied in module packing case - Screw terminal, rising clamp, no internal spring.	 <p>Example showing cable entry and screw terminals of a 10 way connector</p>
Minimum Cable Size	0.5 mm <sup>2</sup> (AWG 20)	
Maximum Cable Size	2.5 mm <sup>2</sup> (AWG 13)	
Tightening Torque	0.5 Nm (4.5 lb-in)	
Wire Strip Length	7 mm (9/32")	

### 2.4 POWER SUPPLY REQUIREMENTS

Description	Specification
Minimum Supply Voltage	8 V continuous, 5 V for up to 1 minute.
Cranking Dropouts	Able to survive 0 V for 100 ms providing the supply was at least 10 V before the dropout and recovers to 5 V afterwards.
Maximum Supply Voltage	35 V continuous (60 V protection)
Reverse Polarity Protection	-35 V continuous
Maximum Operating Current	340 mA at 12 V 160 mA at 24 V
Maximum Standby Current	160 mA at 12 V 80 mA at 24 V
Maximum Current When In Sleep Mode	100 mA at 12 V 50 mA at 24 V
Typical Power (Controller On, Heater Off)	3.8 W to 4.1 W
Typical Power (Controller On, Heater On)	6.8 W to 7.1 W

### 2.5 DIGITAL INPUT

Description	Specification
Number	1 available digital input for panel lock functionality
Arrangement	Contact between terminal and ground
Low Level Threshold	2.1 V minimum
High Level Threshold	6.6 V maximum
Maximum Input Voltage	+60 V DC with respect to plant supply negative
Minimum Input Voltage	-24 V DC with respect to plant supply negative
Contact Wetting Current	5 mA typical
Open Circuit Voltage	12 V typical

## 2.6 OUTPUTS E & F

Description	Specification
Type	Factory set to “audible alarm”, supplied from DC supply terminal 2.
Rating	2 A resistive at plant supply

## 2.7 COMMUNICATION PORTS

 **NOTE: All communication ports can be used at the same time.**

Description	Specification
USB Slave Port	<p>For connection to PC running DSE Configuration Suite</p> <p>Non-isolated Type B USB 2.0 Max distance 6 m (20 feet)</p>
RS232 Serial Port	<p>For connection to a single DSE7xxx MKII module’s RS232 port to act as a Remote Display module. Also acts as a MODBUS passthrough port when the DSE25xx MKII DSENet port is connected to the DSE7xxx MKII module’s RS485 port.</p> <p>Non – isolated Max Baud rate 115 kbaud subject to configuration TX, RX, RTS, CTS, DSR, DTR, DCD Male 9-way D type connector Max distance 15 m (50 feet)</p>
RS485 Serial Port	<p>For connection to a single DSE7xxx MKII module’s DSENet port to act as a DSENet expansion module. Also acts as a MODBUS passthrough port when the DSE25xx MKII is connected to the DSE7xxx MKII module’s RS232 or RS485 ports.</p> <p>Isolated Data connection 2 wire + common Half Duplex Data direction control for Transmit (by s/w protocol) Max Baud Rate 115 kbaud subject to configuration External termination required (120 Ω) Max common mode offset 70 V (on board protection transorb) Max distance 1.2 km (¾ mile)</p>
DSENet® (Expansion Comms) Port	<p>For connection to a single DSE7xxx MKII module’s RS485 port to act as a Remote Display module.</p> <p>Non-isolated Data connection 2 wire + common Half Duplex Data direction control for Transmit (by s/w protocol) Baud Rate of 115 kbaud Internal termination fitted (120 Ω) Max common mode offset ±5 V Max distance 1.2 km (¾ mile)</p>

## 2.8 COMMUNICATION PORT USAGE

### 2.8.1 USB SLAVE PORT (PC CONFIGURATION)

**NOTE:** DSE stock 2 m (6.5 feet) USB type A to type B cable, DSE Part Number: 016-125. Alternatively they are purchased from any PC or IT store.

**NOTE:** The DC supply must be connected to the module for configuration by PC.

**NOTE:** For further details of module configuration, refer to relevant *DSE Module's Configuration Suite Software Manual*.

The USB port is provided to give a simple means of connection between a PC and the controller. Using the DSE Configuration Suite Software, the operator is then able to control the module, starting or stopping the engine, selecting operating modes, etc.

Additionally, the various module options and communication parameters are available to be viewed or changed.

To connect a module to a PC by USB, the following items are required:

DSE73xx MKII Controller



DSE Configuration Suite PC Software  
(Available from [www.deepseaelectronics.com](http://www.deepseaelectronics.com))

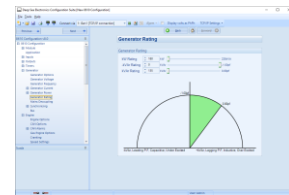

USB cable Type A to Type B.  
(This is the same cable as often used between a PC and a USB printer)



## 2.8.2 RS232 PORT

**NOTE:** For direct connection an RS232 null modem (crossover) cable is required. This is rated to a maximum cable length of 15 m.

### 2.8.2.1 REMOTE DISPLAY CONNECTION

When connected to a DSE7xxx MKII using RS232, the DSE25xx MKII operates as a *Remote Display*. This enables the operator to view various operating parameters (such as coolant temperature, oil pressure, etc.) and change the operating mode of the DSE7xxx MKII using the DSE25xx MKII.

As the RS232 port on the DSE25xx MKII is used to provide the *Remote Display* connection, its RS485 port is available as a MODBUS Passthrough connection. For further details refer to section entitled *RS485 Port* elsewhere within this document.

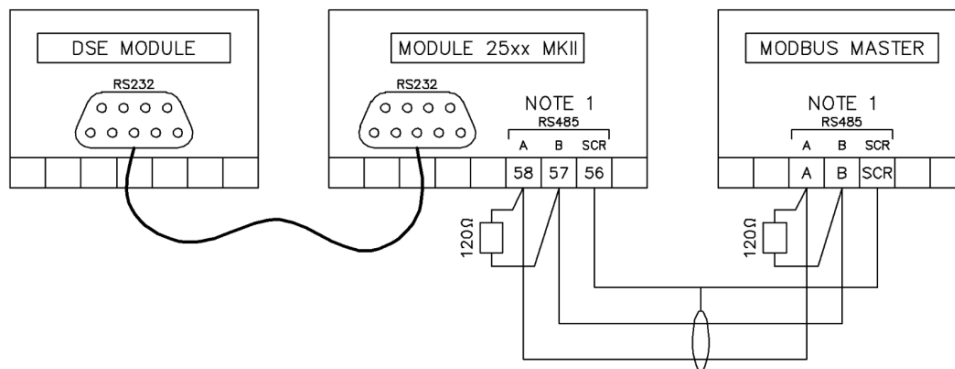

NOTE 1.  
IF THE MODULE IS FIRST OR LAST UNIT ON THE LINK IT MUST BE FITTED WITH AN EXTERNAL 120 OHM TERMINATION RESISTOR ACROSS TERMINALS A AND B TERMINALS.

### 2.8.2.2 MODBUS PASSTHROUGH CONNECTION

When the DSE25xx MKII module's DSENet port is connected to a DSE7xxx MKII module's RS485, the DSE25xx MKII module's RS232 port is available as a MODBUS Passthrough connection.

The MODBUS register table for the controller is available upon request from the DSE Technical Support Department.

Many PCs are not fitted with an internal RS232 serial port. DSE DOES NOT recommend the use of USB to RS232 converters but can recommend PC add-ons to provide the computer with an RS232 port.

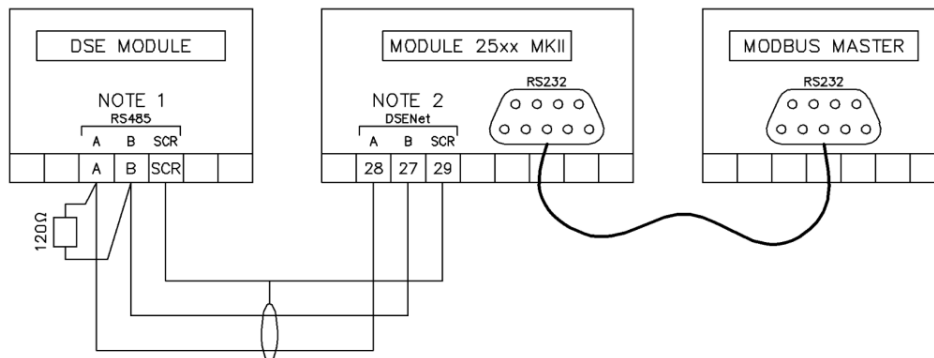

NOTE 1.  
IF THE MODULE IS FIRST OR LAST UNIT ON THE LINK IT MUST BE FITTED WITH AN EXTERNAL 120 OHM TERMINATION RESISTOR ACROSS TERMINALS A AND B TERMINALS.

NOTE 2.  
MUST BE FITTED AS FIRST OR LAST UNIT ON THE LINK WITH NO EXTERNAL TERMINATION RESISTOR

2.8.2.3 CABLE SPECIFICATION

**NOTE:** For direct connection an RS232 null modem (crossover) cable is required. This is rated to a maximum cable length of 15 m.

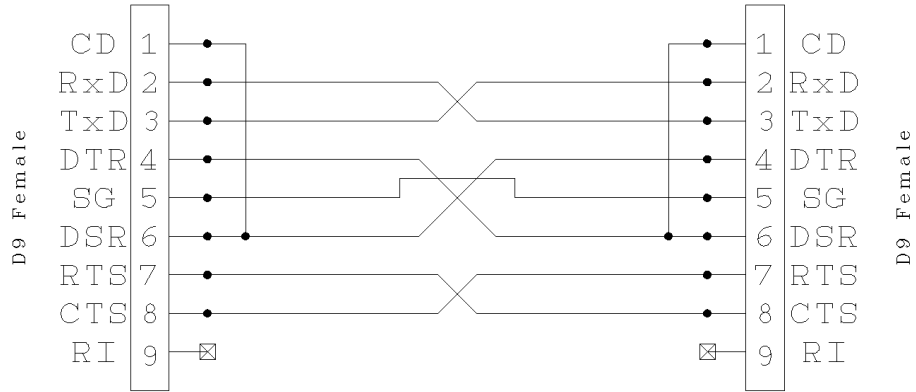

D9 Null Modem Cable Wiring Diagram.

PIN No	Notes
1	Received Line Signal Detector (Data Carrier Detect)
2	Received Data
3	Transmit Data
4	Data Terminal Ready
5	Signal Ground
6	Data Set Ready
7	Request To Send
8	Clear To Send
9	Ring Indicator

### 2.8.3 RS485 PORT

**NOTE:** DSE recommends Belden 9841 (or equivalent) cable. This is rated to a maximum cable length of 1.2 km. DSE Stock Belden 9841 cable, DSE Part Number: 016-030.

#### 2.8.3.1 DSENET EXPANSION CONNECTION

**NOTE:** Enabling the DSE25xx MKII as a DSENet Expansion on the DSE7xxx MKII module reduces the total number of the expansion units from twenty down to five expansion modules, with only a single Battery Charger unit.

When the RS485 port of a DSE25xx MKII module is connected to the DSENet port of a DSE7xxx MKII module, the DSE25xx MKII module operates as a *DSENet Expansion*. This enables the operator to view various operating parameters (such as coolant temperature, oil pressure, etc.) and change the operating mode of the DSE7xxx MKII using the DSE25xx MKII. The MODBUS Passthrough function of the DSE25xx MKII module is disabled.

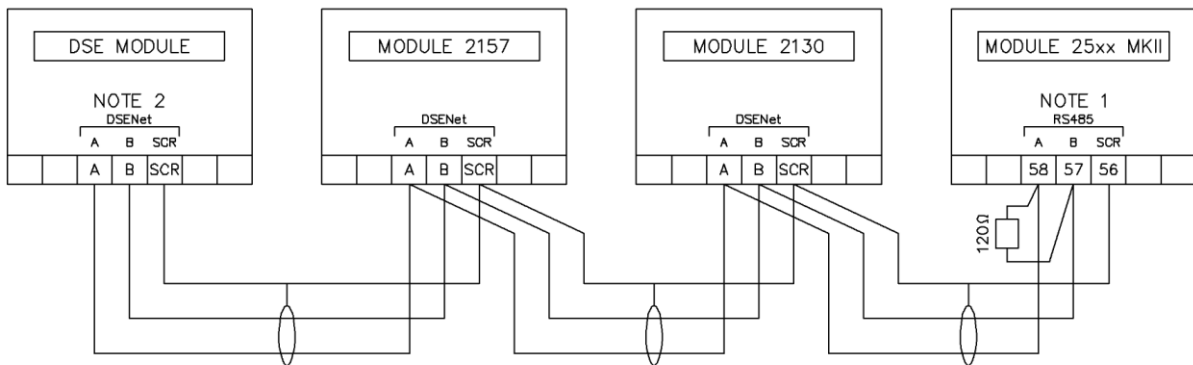

NOTE 1.  
IF THE MODULE IS FIRST OR LAST UNIT ON THE LINK IT MUST BE FITTED WITH AN EXTERNAL 120 OHM TERMINATION RESISTOR ACROSS TERMINALS A AND B TERMINALS.

NOTE 2.  
MUST BE FITTED AS FIRST OR LAST UNIT ON THE LINK WITH NO EXTERNAL TERMINATION RESISTOR

#### 2.8.3.2 MODBUS PASSTHROUGH CONNECTION

When the DSE25xx MKII module's RS232 / DSENet port is connected to a DSE7xxx MKII module's RS232 / RS485 port, the DSE25xx MKII module's RS485 port is available as a MODBUS Passthrough connection.

The DSE MODBUS register table for the controller is available upon request from the DSE Technical Support Department.

RS485 is used for point-to-point cable connection of more than one device (maximum 32 devices) and allows for connection to PCs, PLCs and Building Management Systems (to name just a few devices).

One advantage of the RS485 interface is the large distance specification (1.2 km when using Belden 9841 (or equivalent) cable). This allows for a large distance between the module and a PC running the DSE Configuration Suite software. The operator is then able to control the module, starting or stopping the engine, selecting operating modes, etc.

Many PCs are not fitted with an internal RS485 serial port. DSE DOES NOT recommend the use of USB to RS485 converters but can recommend PC add-ons to provide the computer with an RS485 port.

**Using RS485 as MODBUS Passthrough With:**

**DSENet (DSE25xx MKII) to RS485 (DSE7xxx MKII)**

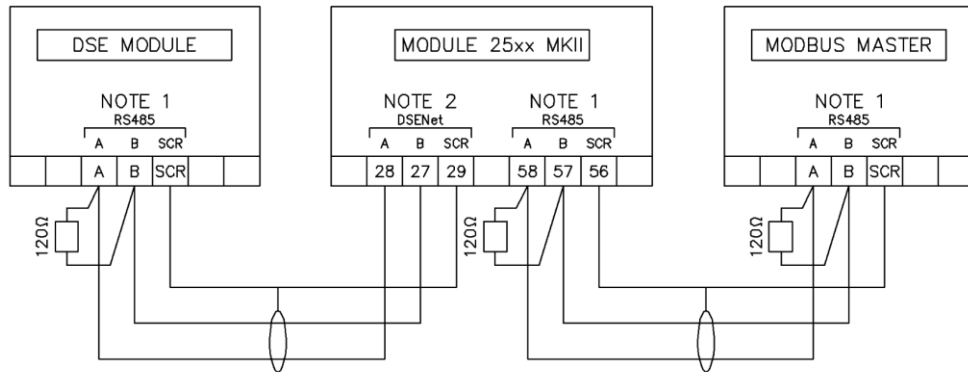

NOTE 1.  
IF THE MODULE IS FIRST OR LAST UNIT ON THE LINK IT MUST BE FITTED WITH AN EXTERNAL 120 OHM TERMINATION RESISTOR ACROSS TERMINALS A AND B TERMINALS.

NOTE 2.  
MUST BE FITTED AS FIRST OR LAST UNIT ON THE LINK WITH NO EXTERNAL TERMINATION RESISTOR

**RS232 (DSE25xx MKII) to RS232 (DSE7xxx MKII)**

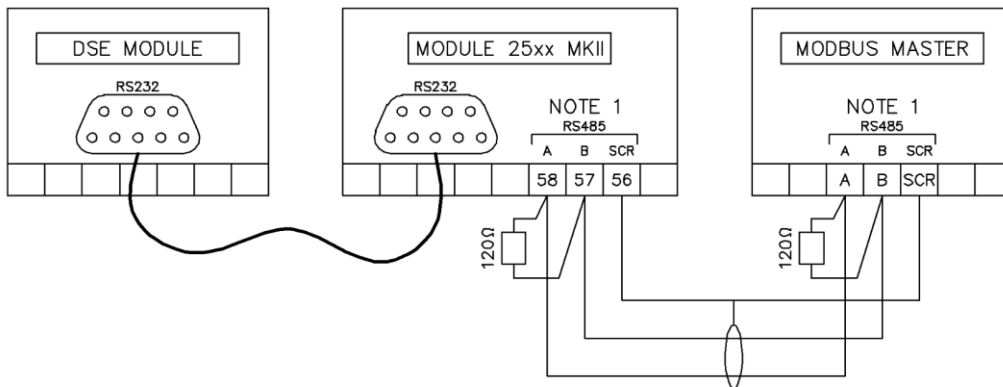

NOTE 1.  
IF THE MODULE IS FIRST OR LAST UNIT ON THE LINK IT MUST BE FITTED WITH AN EXTERNAL 120 OHM TERMINATION RESISTOR ACROSS TERMINALS A AND B TERMINALS.

**2.8.3.3 CABLE SPECIFICATION**

**▲ NOTE: DSE recommend Belden 9841 (or equivalent) cable for RS485 communication. This is rated to a maximum cable length of 1.2 km. DSE Stock Belden 9841 cable, DSE Part Number: 016-030.**

Description	Specification
Cable Type	Two core screened and shielded twisted pair
Cable Characteristics	120 Ω impedance Low capacitance
Recommended Cable	Belden 9841 Belden 9271
Maximum Cable Length	1200 m (¾ mile) when using Belden 9841 or direct equivalent. 600 m (656 yards) when using Belden 9271 or direct equivalent.
RS485 Topology	“Daisy Chain” Bus with no stubs (spurs)

## 2.8.4 DSENET®

### 2.8.4.1 REMOTE DISPLAY CONNECTION

When the DSE25xx MKII module's DSENet port is connected to a DSE7xxx MKII module's RS485 port, the DSE25xx MKII operates as a *Remote Display*. This enables the operator to view various operating parameters (such as coolant temperature, oil pressure, etc.) and change the operating mode of the DSE7xxx MKII using the DSE25xx MKII.

As the DSENet port on the DSE25xx MKII is used to provide the *Remote Display* connection, it's RS232 and RS485 port is available as a MODBUS Passthrough connection. For further details refer to section entitled *RS232 Port* and *RS485 Port* elsewhere within this document.

### RS485 MODBUS Passthrough

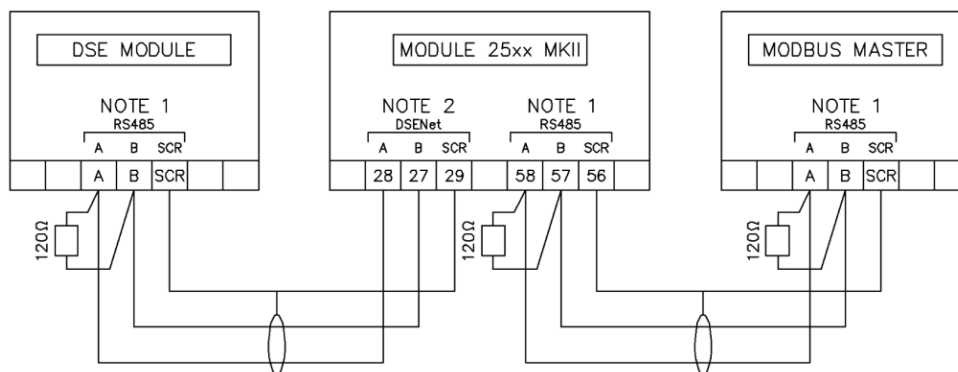

NOTE 1.  
IF THE MODULE IS FIRST OR LAST UNIT ON THE LINK IT MUST BE FITTED WITH AN EXTERNAL 120 OHM TERMINATION RESISTOR ACROSS TERMINALS A AND B TERMINALS.

NOTE 2.  
MUST BE FITTED AS FIRST OR LAST UNIT ON THE LINK WITH NO EXTERNAL TERMINATION RESISTOR

### RS232 MODBUS Passthrough

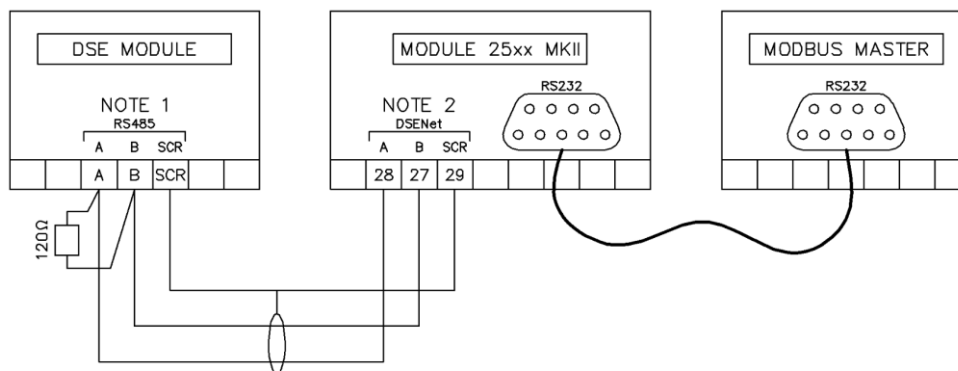

NOTE 1.  
IF THE MODULE IS FIRST OR LAST UNIT ON THE LINK IT MUST BE FITTED WITH AN EXTERNAL 120 OHM TERMINATION RESISTOR ACROSS TERMINALS A AND B TERMINALS.

NOTE 2.  
MUST BE FITTED AS FIRST OR LAST UNIT ON THE LINK WITH NO EXTERNAL TERMINATION RESISTOR



2.8.4.2 CABLE SPECIFICATION

**▲ NOTE: DSE recommends Belden 9841 (or equivalent) cable for DSENet® communication. This is rated to a maximum cable length of 1.2 km. DSE Stock Belden 9841 cable, DSE Part Number: 016-030.**

DSENet® is the interconnection cable between the DSE25xx MKII display and the DSE host controller and must not be connected to any device other than DSE equipment designed for connection to the DSENet®.

Description	Specification
Cable Type	Two core screened and shielded twisted pair
Cable Characteristics	120 Ω Low capacitance
Recommended Cable	Belden 9841 Belden 9271
Maximum Cable Length	1200 m (¾ mile) when using Belden 9841 or direct equivalent. 600 m (656 yards) when using Belden 9271 or direct equivalent.
DSENet® Topology	“Daisy Chain” Bus with no stubs (spurs)

## 2.9 SOUNDER

The display features an internal sounder to draw attention to warning, shutdown and electrical trip alarms. This operates at the same time as the host controller's internal sounder and can be muted locally. Operation of the mute function is subject to the configuration of the host controller and may be either 'follow main unit' or local.

When 'follow main unit' is selected, pressing any mute button in the system on the host controller or on any other DSENet® module configured to "follow main unit" will silence the host controller and all modules configured to 'follow main unit'.

When 'follow main unit' is not selected, the display mute button operates independent of any other DSENet® or host controller mute button.

<b>Description</b>	<b>Specification</b>
Sounder level	84db @ 1m

## 2.10 DIMENSIONS AND MOUNTING

### 2.10.1 DIMENSIONS

245 mm x 184 mm x 51 mm  
(9.6" x 7.2" x 2.0")

### 2.10.2 PANEL CUTOUT

220 mm x 159 mm  
(8.7" x 6.3")

### 2.10.3 WEIGHT

0.98 kg  
(2.16 lb)

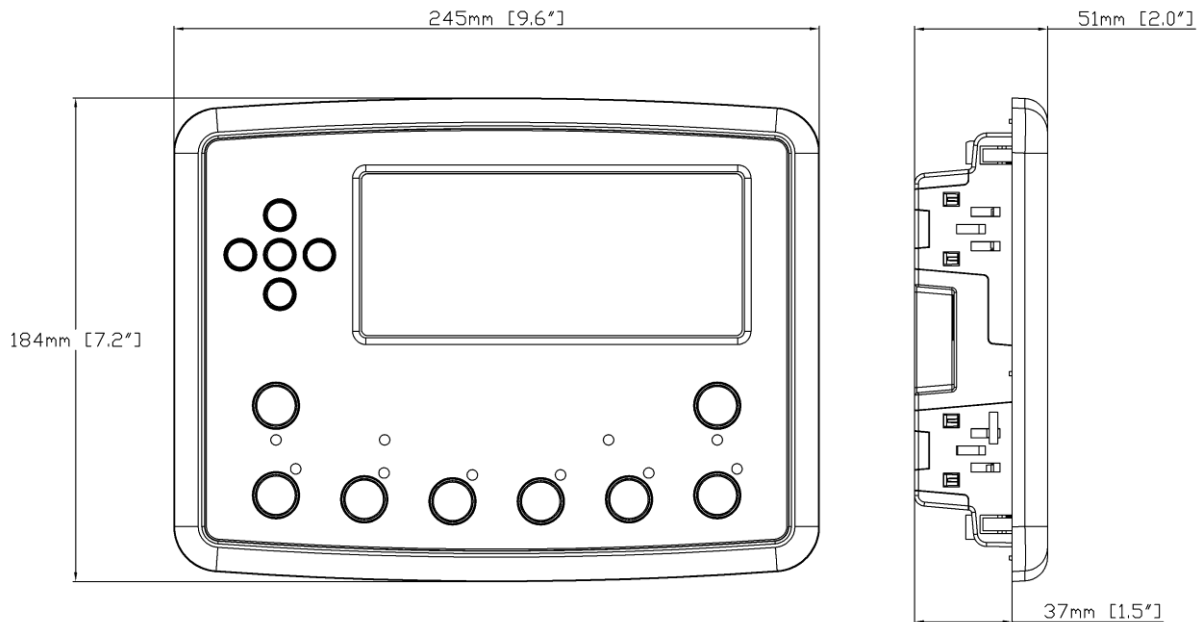

## 2.10.4 FIXING CLIPS

**NOTE:** In conditions of excessive vibration, mount the module on suitable anti-vibration mountings.

The module is held into the panel fascia using the supplied fixing clips.

Withdraw the fixing clip screw (turn anticlockwise) until only the pointed end is protruding from the clip.

Insert the three 'prongs' of the fixing clip into the slots in the side of the module case.

Pull the fixing clip backwards (towards the back of the module) ensuring all three prongs of the clip are inside their allotted slots.

Turn the fixing clip screws clockwise until they make contact with the panel fascia.

Turn the screw a quarter of a turn to secure the module into the panel fascia. Care must be taken not to over tighten the fixing clip screws.

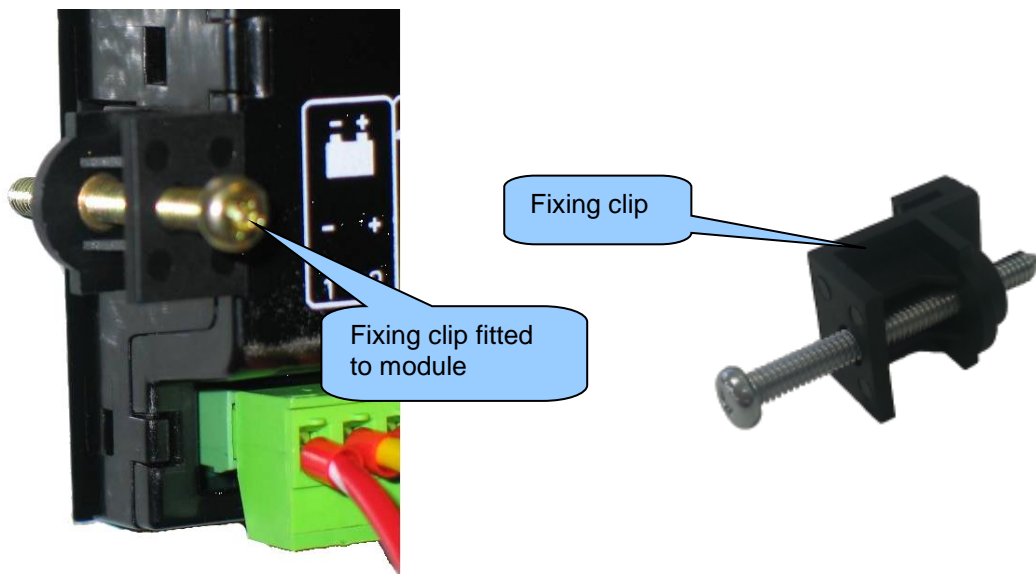

### 2.10.5 CABLE TIE FIXING POINTS

Cable tie fixing points are included on the rear of the module's case to aid wiring. This additionally provides strain relief to the cable loom by removing the weight of the loom from the screw connectors, reducing the chance of future connection failures.

Care must be taken not to over tighten the cable tie (for instance with cable tie tools) to prevent the risk of damage to the module case.



Cable Tie Fixing Point



With Cable And Tie In Place

### 2.10.6 SILICON SEALING GASKET

**NOTE:** For purchasing a silicon gasket from DSE, see the section entitled **Maintenance, Spares, Repair and Servicing** elsewhere in this document.

The silicon gasket provides improved sealing between module and the panel fascia. The gasket is fitted to the module before installation into the panel fascia. Take care to ensure the gasket is correctly fitted to the module to maintain the integrity of the seal.



## 2.11 APPLICABLE STANDARDS

Standard	Description
BS 4884-1	This document conforms to BS4884-1 1992 Specification for presentation of essential information.
BS 4884-2	This document conforms to BS4884-2 1993 Guide to content
BS 4884-3	This document conforms to BS4884-3 1993 Guide to presentation
BS EN 60068-2-1 (Minimum temperature)	-30 °C (-22 °F)
BS EN 60068-2-2 (Maximum temperature)	+70 °C (158 °F)
BS EN 60950	Safety of information technology equipment, including electrical business equipment
BS EN 61000-6-2	EMC Generic Immunity Standard (Industrial)
BS EN 61000-6-4	EMC Generic Emission Standard (Industrial)
BS EN 60529 (Degrees of protection provided by enclosures)	IP65 (front of module when installed into the control panel with the optional sealing gasket) IP42 (front of module when installed into the control panel WITHOUT being sealed to the panel)
UL508 NEMA rating (Approximate)	12 (Front of module when installed into the control panel with the optional sealing gasket). 2 (Front of module when installed into the control panel WITHOUT being sealed to the panel)

In line with our policy of continual development, Deep Sea Electronics Ltd, reserve the right to change specification without notice.

## 2.11.1 ENCLOSURE CLASSIFICATIONS

### 2.11.1.1 IP CLASSIFICATIONS

The modules specification under BS EN 60529 Degrees of protection provided by enclosures

<b>IP65</b> (Front of module when module is installed into the control panel with the optional sealing gasket).
<b>IP42</b> (front of module when module is installed into the control panel WITHOUT being sealed to the panel)

First Digit	Second Digit
Protection against contact and ingress of solid objects	Protection against ingress of water
0 No protection	0 No protection
1 Protected against ingress solid objects with a diameter of more than 50 mm. No protection against deliberate access, e.g. with a hand, but large surfaces of the body are prevented from approach.	1 Protection against dripping water falling vertically. No harmful effect must be produced (vertically falling drops).
2 Protected against penetration by solid objects with a diameter of more than 12 mm. Fingers or similar objects prevented from approach.	2 Protection against dripping water falling vertically. There must be no harmful effect when the equipment (enclosure) is tilted at an angle up to 15° from its normal position (drops falling at an angle).
3 Protected against ingress of solid objects with a diameter of more than 2.5 mm. Tools, wires etc. with a thickness of more than 2.5 mm are prevented from approach.	3 Protection against water falling at any angle up to 60° from the vertical. There must be no harmful effect (spray water).
4 Protected against ingress of solid objects with a diameter of more than 1 mm. Tools, wires etc. with a thickness of more than 1 mm are prevented from approach.	4 Protection against water splashed against the equipment (enclosure) from any direction. There must be no harmful effect (splashing water).
5 Protected against harmful dust deposits. Ingress of dust is not totally prevented but the dust must not enter in sufficient quantity to interface with satisfactory operation of the equipment. Complete protection against contact.	5 Protection against water projected from a nozzle against the equipment (enclosure) from any direction. There must be no harmful effect (water jet).
6 Protection against ingress of dust (dust tight). Complete protection against contact.	6 Protection against heavy seas or powerful water jets. Water must not enter the equipment (enclosure) in harmful quantities (splashing over).

2.11.1.2 NEMA CLASSIFICATIONS

 **NOTE: There is no direct equivalence between IP / NEMA ratings. IP figures shown are approximate only.**

**12** (Front of module when module is installed into the control panel with the optional sealing gasket).  
**2** (Front of module when module is installed into the control panel WITHOUT being sealed to the panel)

1 <b>IP30</b>	Provides a degree of protection against contact with the enclosure equipment and against a limited amount of falling dirt.
2 <b>IP31</b>	Provides a degree of protection against limited amounts of falling water and dirt.
3 <b>IP64</b>	Provides a degree of protection against windblown dust, rain and sleet; undamaged by the formation of ice on the enclosure.
3R <b>IP32</b>	Provides a degree of protection against rain and sleet; undamaged by the formation of ice on the enclosure.
4 (X) <b>IP66</b>	Provides a degree of protection against splashing water, windblown dust and rain, hose directed water; undamaged by the formation of ice on the enclosure. (Resist corrosion).
12/12K <b>IP65</b>	Provides a degree of protection against dust, falling dirt and dripping non- corrosive liquids.
13 <b>IP65</b>	Provides a degree of protection against dust and spraying of water, oil and non- corrosive coolants.



### 3 CONVERSION

**NOTE:** The DSE25xx MKII remote display unit is converted back to a DSE73xx MKII controller using a firmware file of the DSE73xx MKII.

The DSE25xx MKII display module is available as a firmware update for the DSE73xx MKII controllers. This allows the user to convert an existing DSE7310 MKII module to a DSE2510 MKII or a DSE7320 MKII controller to a DSE2520 MKII remote display unit, using the DSE Configuration Suite PC Software by following the firmware update procedure. After conversion, the DSE2510 MKII remote display unit is compatible with either a DSE7310 MKII or a DSE7410 MKII controller; and, the DSE2520 MKII is compatible with either a DSE7320 MKII or a DSE7420 MKII module.

#### 3.1 UPDATE FIRMWARE

Selecting *Update Firmware* initiates the update wizard:

Click the **exit** button to cancel the update.

**Hint :** Stopping the update process once it begins could leave the module inoperable! If this occurs, simply run the update wizard again and let it complete correctly.

Click **next** to continue.

Select the device type

Click **next** to continue.

## Conversion

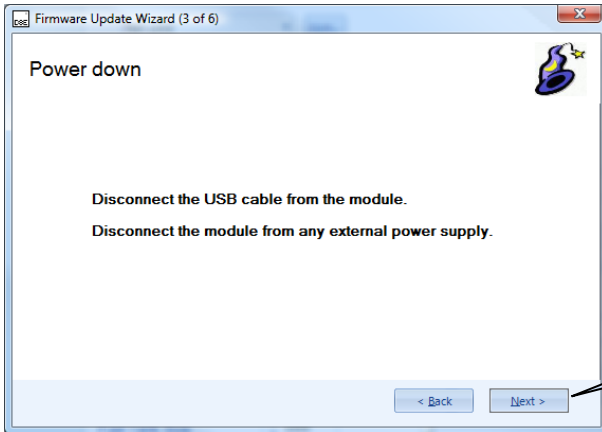

Ensure the module's supply and USB cable are removed, and then click **next** to

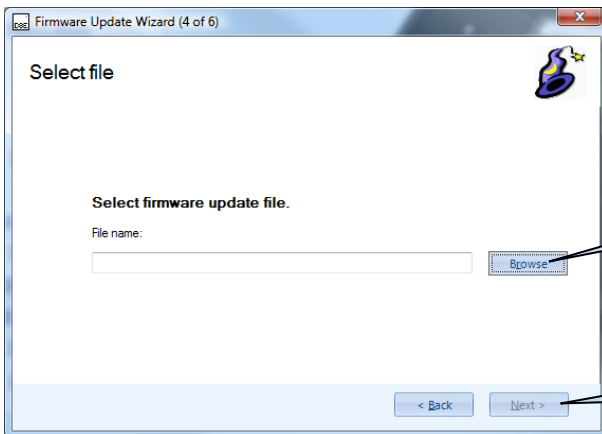

Click to select the firmware update file.

Then click **next** to continue.

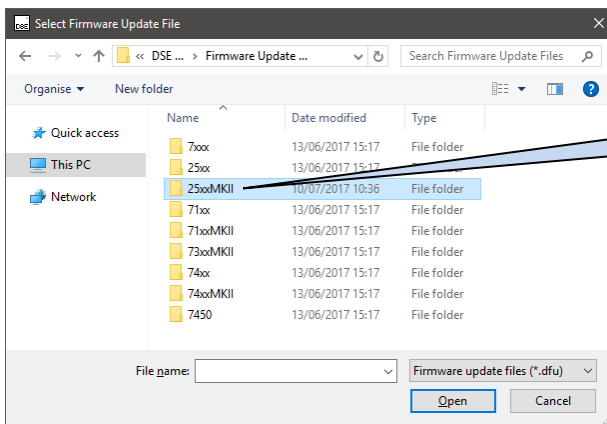

Open the 25xxMKII folder to select the firmware file.

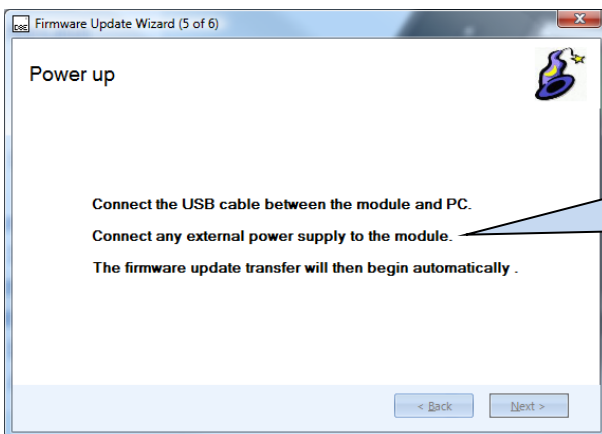

Ensure the USB cable is connected before the module's power supply. It will be automatically detected and the update process will begin.

## Conversion

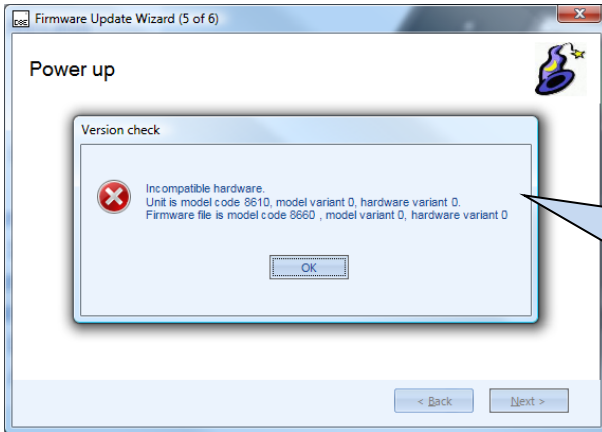

If the file you attempt to send to the module is not compatible with the currently connected module, the update cannot continue.

In this example an attempt was made to send a DSE8660 firmware file to a DSE8610 module!

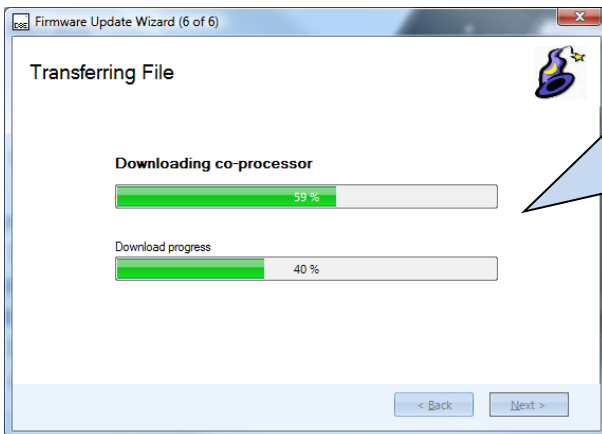

The update is now in progress and will take under one minute.

During this phase:

- DO NOT DISCONNECT THE USB CONNECTION
- DO NOT TURN OFF YOUR PC
- DO NOT REMOVE POWER

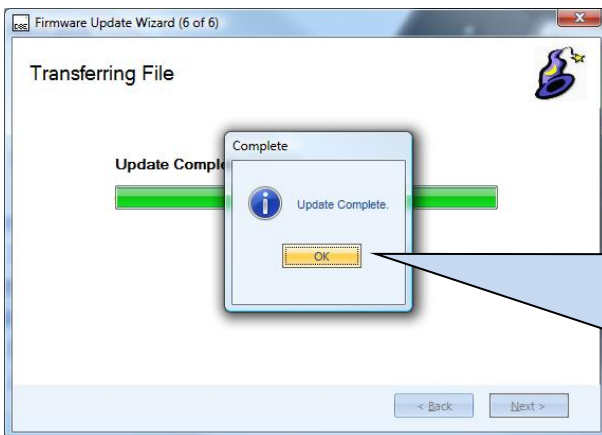

The update is now complete.

The module will automatically restart with the updated firmware (internal software program).

It is now safe to disconnect the USB lead and power down the module or your PC.

Click **OK** to continue.

## 4 INSTALLATION

The module is designed to be mounted on the panel fascia. For dimension and mounting details, see the section entitled *Dimension and Mounting* elsewhere in this document.

### 4.1 USER CONNECTIONS





 **NOTE: Terminals 3 to 7 are not used on the DSE25xx MKII series controller.**

 **NOTE: Terminals 10 to 26 are not used on the DSE25xx MKII series controller.**

 **NOTE: Terminals 30 to 47 are not used on the DSE25xx MKII series controller.**

 **NOTE: Terminals 49 to 55 are not used on the DSE25xx MKII series controller.**

 **NOTE: Screened 120Ω impedance cable specified for use with RS485 must be used for the RS485 and DSENET® connections.  
DSE stock and supply Belden cable 9841 which is a high quality 120Ω impedance cable suitable for RS485 and DSENET® use (DSE part number 016-030)**

	Pin No	Description	Cable Size	Notes
	1	DC Plant Supply Input (Negative)	2.5 mm <sup>2</sup> AWG 13	Connect to ground where applicable.
	2	DC Plant Supply Input (Positive)	2.5 mm <sup>2</sup> AWG 13	Supplies the module and DC Outputs E, F, G, H, I & J
	8	DC Output E	1.0 mm <sup>2</sup> AWG 18	Plant Supply Positive from terminal 2. 2 A DC rated.
	9	DC Output F	1.0 mm <sup>2</sup> AWG 18	Plant Supply Positive from terminal 2. 2 A DC rated.
	27	DSENet® Expansion B	0.5 mm <sup>2</sup> AWG 20	Use only 120 Ω CAN or RS485 approved cable
	28	DSENet® Expansion A	0.5 mm <sup>2</sup> AWG 20	Use only 120 Ω CAN or RS485 approved cable
	29	DSENet® Expansion Screen	Shield	Use only 120 Ω CAN or RS485 approved cable
	48	Configurable Digital Input A	0.5 mm <sup>2</sup> AWG 20	Switch To Negative
RS485	56	RS485 Port Screen	Shield	Use only 120 Ω CAN or RS485 approved cable
	57	RS485 Port B (+)	0.5 mm <sup>2</sup> AWG 20	Connect to RXD+ and TXD+ Use only 120 Ω CAN or RS485 approved cable
	58	RS485 Port A (-)	0.5 mm <sup>2</sup> AWG 20	Connect to RXD- and TXD- Use only 120 Ω CAN or RS485 approved cable

### 4.1.1 RS232

**NOTE:** For further details of module configuration, refer to relevant *DSE Module's Configuration Suite Software Manual*.

Description	Notes
 Socket for connection to a modem or PC with DSE Configuration Suite Software	Supports MODBUS RTU protocol or external modem

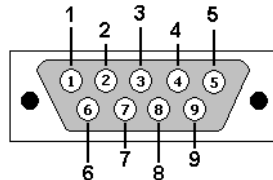

View looking into the male connector on the module



PIN No	Notes
1	Received Line Signal Detector (Data Carrier Detect)
2	Received Data
3	Transmit Data
4	Data Terminal Ready
5	Signal Ground
6	Data Set Ready
7	Request To Send
8	Clear To Send
9	Ring Indicator

### 4.1.2 USB SLAVE (PC CONFIGURATION) CONNECTOR

**NOTE:** The USB connection cable between the PC and the module must not be extended beyond 5 m (yards). For distances over 5 m, it is possible to use a third party USB extender. Typically, they extend USB up to 50 m. The supply and support of this type of equipment is outside the scope of Deep Sea Electronics Ltd.

**CAUTION!** Care must be taken not to overload the PC's USB system by connecting more than the recommended number of USB devices to the PC. For further information, consult your PC supplier.

**NOTE:** For further details of module configuration, refer to relevant *DSE Module's Configuration Suite Software Manual*.

Description	Cable Size	Notes
 Socket for connection to PC with DSE Configuration Suite Software	0.5 mm <sup>2</sup> AWG 20	This is a standard USB type A to type B connector. 

## 4.2 TYPICAL WIRING DIAGRAM

**NOTE:** DSENET® terminals are used for connection to DSE host module. RS485 terminals are used for connection to a Modbus Master for the purpose of Modbus Passthrough and for connection to a single DSE host module.

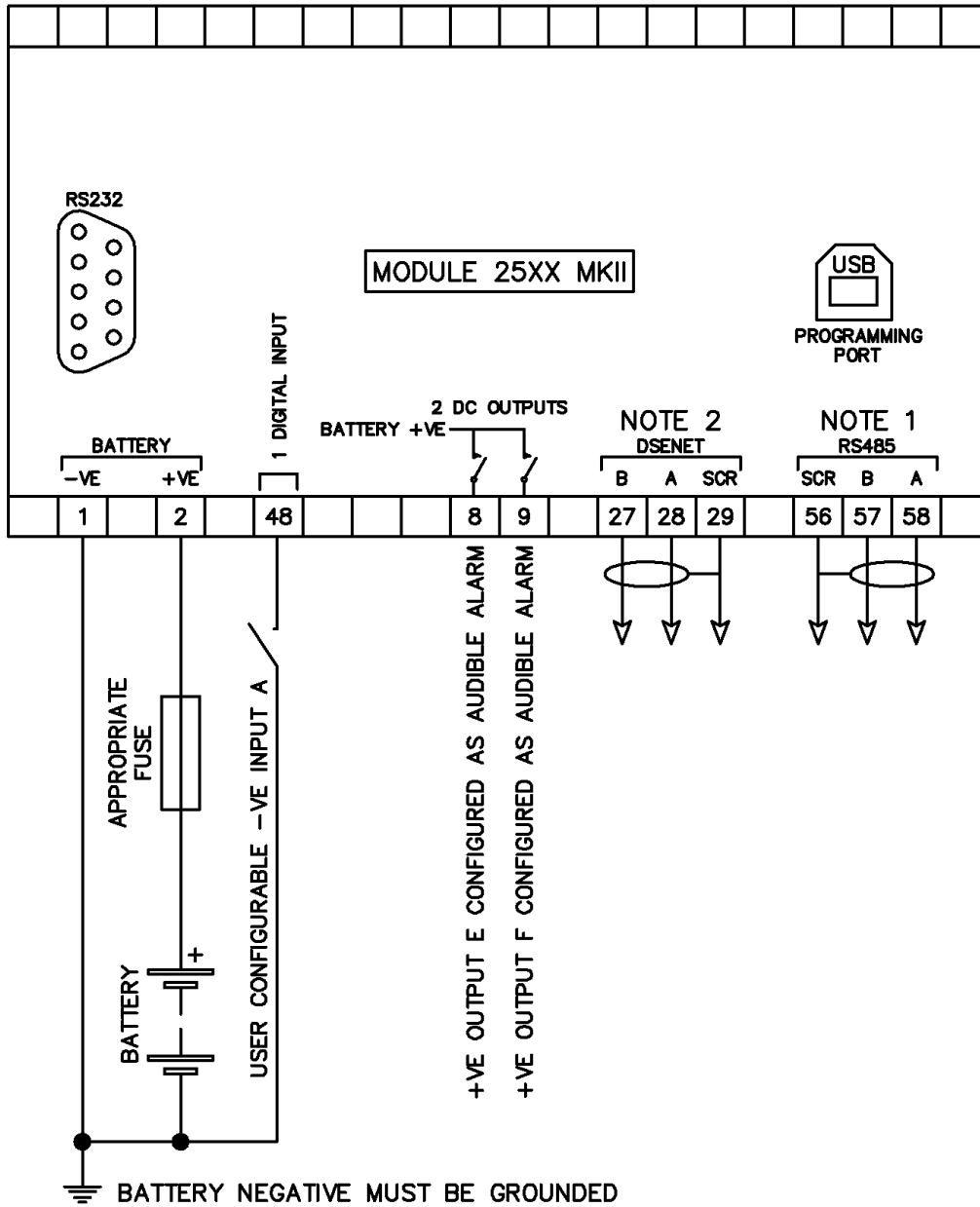

**NOTE 1.** IF THE MODULE IS FIRST OR LAST UNIT ON THE LINK IT MUST BE FITTED WITH AN EXTERNAL 120 OHM TERMINATION RESISTOR ACROSS TERMINALS A AND B.

**NOTE 2.** MUST BE FITTED AS FIRST OR LAST UNIT ON THE LINK WITH NO EXTERNAL TERMINATION RESISTOR

#### 4.2.1 WIRING TO A DSE7XXX MKII MODULE.

 **NOTE:** For further details on wiring to a DSE7xxx MKII module, refer to section entitled *Communication Port Usage* elsewhere within this document.

## 5 CONTROLS AND INDICATIONS

 **NOTE: All navigation buttons of the main controller are observed by the DSE25xx MKII remote display unit, with exception to the *Tick* button. Accessing the Front Panel Editor on the main unit has no effect on the remote display; as well as the Running Editor is different between the two and is accessed individually on each unit.**

The DSE25xx MKII remote display is designed to mimic the operation and display of the main unit. It observes the control and navigation buttons of the main unit to mimic the control and display. When an instrumentation page is viewed on the main controller's LCD screen, the same page is shown on the DSE25xx MKII remote display.



## 6 FRONT PANEL CONFIGURATION

This configuration mode allows the operator limited customising of the way the display module operates. Host controller configuration is not available from the fascia of the DSE25xx series display module.

Use the module's navigation buttons to traverse the menu and make value changes to the parameters:

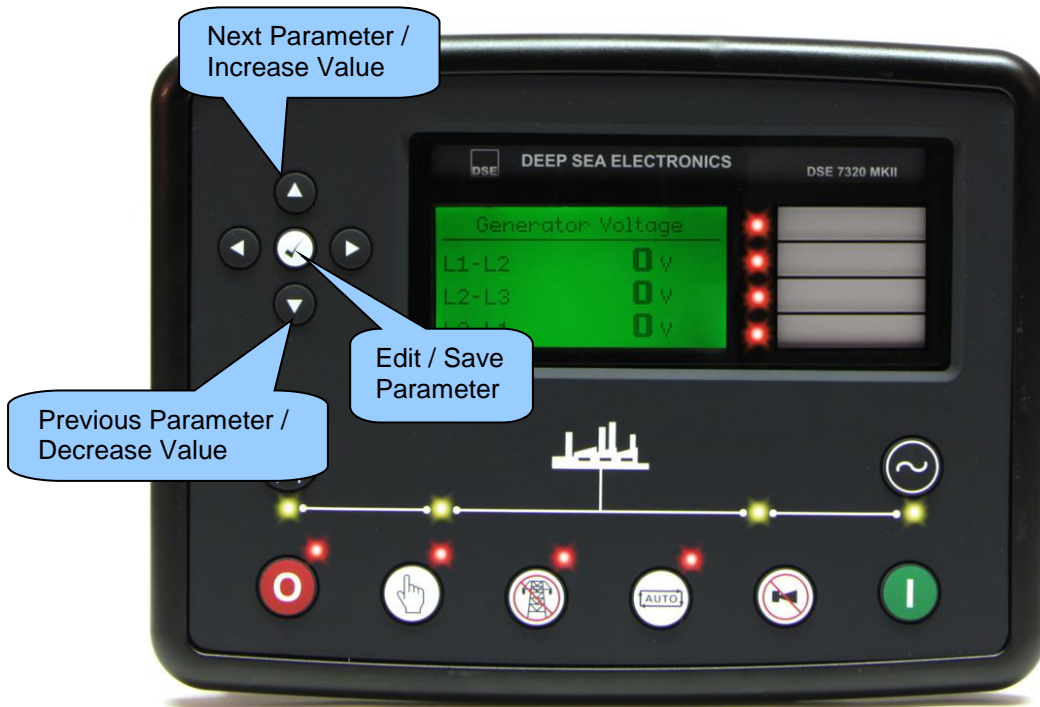

## 6.1 ACCESSING THE 'RUNNING' CONFIGURATION EDITOR

**NOTE:** All navigation buttons of the main controller are observed by the DSE25xx MKII remote display unit, with exception to the *Tick* button. Accessing the Front Panel Editor on the main unit has no effect on the remote display; as well as the Running Editor is different between the two and is accessed individually on each unit.

- The *Running Editor* is accessible whilst the generator is running. All protections remain active when the generator is running while the *Running Editor* is entered



- Press and hold the *Tick* button to access the *Running Editor*.

### 6.1.1 EDITING A PARAMETER

**NOTE:** Pressing and holding the *Menu Navigation* buttons provides the auto-repeat functionality. Values can be changed quickly by holding the navigation buttons for a prolonged period of time.



- Press the *Right* or *Left* buttons to cycle to the section to view/change.
- Press the *Up* or *Down* buttons to select the parameter to view/change within the currently selected section.
- To edit the parameter, press the *Tick* button to enter edit mode. The parameter begins to flash to indicate editing.
- Press the *Up* or *Down* buttons to change the parameter to the required value.
- Press the *Tick* button to save the value. The parameter ceases flashing to indicate that it has been saved.

**6.1.2 ADJUSTABLE PARAMETERS (RUNNING EDITOR)**

<b>Section</b>	<b>Parameter As Shown On Display</b>	<b>Value</b>
<b>Display</b>	Contrast	0 %
	Language	English
	LCD Page Delay	0 h 0 m 0 s
	Scroll Delay	0 h 0 m 0 s
	Backlight Power Saving	Active / Inactive
	Backlight Timer	0 h 0 m 0 s
	Sleep Mode	Active / Inactive
	Sleep Timer	0 h 0 m 0 s
	Sounder	Active / Inactive
	Follow Main Unit	Active / Inactive
	Auto Mute Timer	Active / Inactive
	Auto Mute Timer	0 h 0 m 0 s
	Control Buttons	Active / Inactive
	Digital Input A for Remote Panel Lock	Active / Inactive
	<b>Display Port</b>	Display Port
Baud		9600 to 115200
Slave ID		0
Packet Timeout		0 ms
<b>Pass Through Port</b>	Pass Through Port	Active / Inactive
	Baud	9600 to 115200
	Slave ID	0
	Master Inactivity Timeout	0 h 0 m 0 s
	Interframe Delay	0 ms
<b>About</b>	Variant	25xx
	Application	V0.0.0
	USB ID	0
	Bootloader	V0.0.0

## 7 MAINTENANCE, SPARES, REPAIR AND SERVICING

The controller is *Fit and Forget*. As such, there are no user serviceable parts within the controller. In the case of malfunction, you should contact your original equipment manufacturer (OEM).

### 7.1 PURCHASING ADDITIONAL FIXING CLIPS FROM DSE

Item	Description	Part No.
	7000 series fixing clips (packet of 4)	020-294

### 7.2 PURCHASING ADDITIONAL SEALING GASKET FROM DSE

Item	Description	Part No.
	Module Silicon Sealing Gasket	020-564

## 8 FAULT DIAGNOSIS

Nature of problem	Suggestion
Module appears to be 'dead'	Check polarity and size of the connected DC supply are within the specifications of the DSE25xx MKII module.
Host controller indicates there is a fault with communications with the remote display unit.	Check the connection of the DSENet® on the DSE25xx MKII unit, paying particular attention to the cable type being used. Check the connection on the Modbus port of the host controller, paying attention to the positioning of the termination resistor. Check both controllers' configuration and refer to the relevant DSE controller software manual.

## 9 WARRANTY

DSE provides limited warranty to the equipment purchaser at the point of sale. For full details of any applicable warranty, you are referred to your original equipment supplier (OEM).

## 10 DISPOSAL

### 10.1 WEEE (WASTE ELECTRICAL AND ELECTRONIC EQUIPMENT)

Directive 2002/96/EC

If you use electrical and electronic equipment you must store, collect, treat, recycle and dispose of WEEE separately from your other waste.



*This Page Intentionally Left Blank*